

ROBOTIER ROBOTIC PALLETIZERS

RoboTier Robotic
Palletizers –
Innovation in Motion

TopTier's RoboTier Robotic Palletizers to transform and streamline your shipping process. Engineered for **precision, efficiency, and versatility**, RoboTier leverages cutting-edge technology and proven engineering to deliver unmatched performance.



Product Capabilities

- **Case Dimensions:** Min 6" – Max 29"
- **Maximum Weight:** 220 lbs
- **Infeed Height:** 23" – 60"
- **Product Types:** Cases, bags, bundles, display trays, and more

Key Features

- **User Interface:** Allen-Bradley PanelView 5310 – 10" color touchscreen
- **Robot:** FANUC industrial robot for high-speed, accurate operation
- **Stretch Wrapper:** Robopac automatic integration for seamless pallet wrapping
- **Conveyors:** TopTier MDR and pallet conveyors for smooth material flow
- **Controls:** Allen-Bradley PLCs & VFDs for higher-speed configurations
- **Safety:** Category 3 compliance for safe operation

Why Choose RoboTier?

RoboTier robotic palletizers offer wide layout flexibility, robust design, and the engineering experience to meet the most demanding production environments.



TopTier palletizers feature **Easy Stack Pro**, the most advanced and easiest to use operator interface on the market. Easy Stack Pro is so intuitive, **new operators begin operating a RoboTier palletizer in under 15 minutes.**

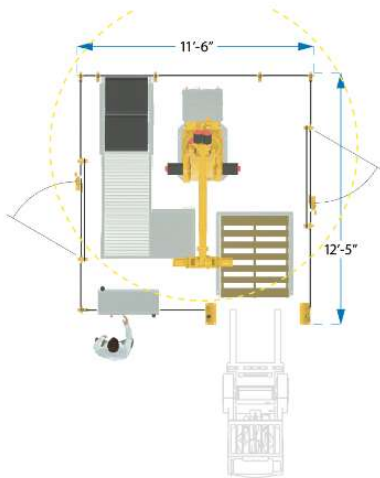

Semi-Automatic > 1-in 1-out

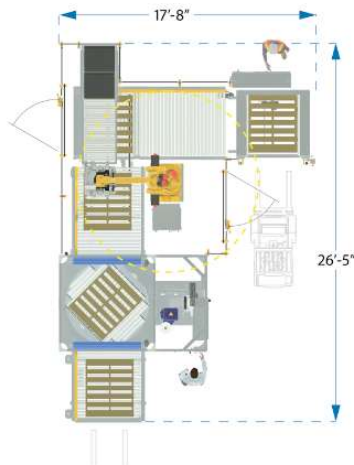

Fully-Automatic > 1-in 1-out > Stretch Wrap

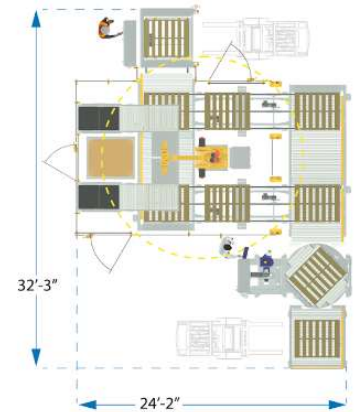

Fully-Automatic > 2-in 2-out > Stretch Wrap

Capabilities

- **Operation:** Semi and fully automatic
- **Configuration:** Single and multiple lanes
- **Rates:** To 3 layers per minute
- **Products:** Case, bag, bundle, display tray, and more
- **Safety Rating:** Cat 3
- **End Effectors:** Side clamp, bottom support, vacuum lift, and more
- **Infeed Height:** 23" to 60"
- **Minimum Case Dimension:** 6"
- **Maximum Case Dimension:** 29"
- **Maximum Case Weight:** 220lbs

Options

- Pallet Handling
- Stretch Wrapping
- Load Handling
- Sheet Station
- Higher Speed Package
- Fence Free Safety Guard
- Custom Pallet Sizes
- Labels-out
- Pallet Labeling
- Freezer Environment
- Panel Cooling
- Tall Load / Double Stack Loads
- Fallen Case Detection
- Video Monitoring
- On site Assembly, Commissioning, Training
- Preventative Maintenance

Components

- **HMI:** AB Panelview 5310 10" Color Touchscreen
- **Robot:** Fanuc
- **Stretch Wrapper:** Robopac Automatic
- **Conveyor:** TopTier MDR and Pallet Conveyors
- **Controls:** Touch-Safe UL-Listed panel
- **Safety Technology:** Troax