

PLURIPAC M

BUBBLE WRAP, FOAM OR POLYETHYLENE REELS COLD PACKAGING DEVICE

The Pluripac M is a bubble wrap, foam or polyethylene reels cold packaging device that is compatible with new or already installed Compacta manual horizontal stretch wrapping machines.

- Product shock protection
- Total closing of the product



Performance features:



MANUAL IMPULSE WELDING

Manual welding of the plastic film on the product and adjustment of the welding time. Fume extraction hood with filter.

LAYOUT COMPACTA + PLURIPAC M

| | COMPACTA 6 + PLURIPAC M6 | COMPACTA 9 + PLURIPAC M9 |
|------|-----------------------------|-----------------------------|
| A mm | 600 max | 900 max |
| B mm | 700 max | 700 max |
| C mm | 800 min / 900 max | 800 min / 920 max |
| D mm | 1880 | 2030 |
| E mm | 1544 | 1850 |
| F mm | 1438 | 1948 |
| G mm | 1100 | 1400 |
| H mm | 1575 | 2030 |
| I mm | 428 | 640 |
| J mm | 570 | 975 |
| K mm | 1046 | 1450 |
| L mm | 1120 | 1120 |
| M mm | 2210 | 2600 |
| N mm | 614 | 950 |
| O mm | 632 | 830 |

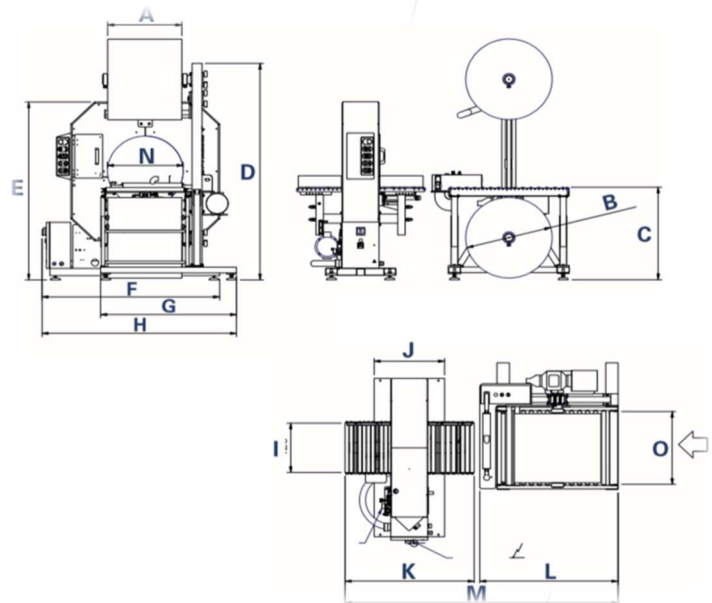

DIMENSIONI PRODOTTO / PRODUCT DIMENSIONS

| MACCHINA / MACHINE | | PLURIPAC M6 | | PLURIPAC M9 | |
|-----------------------------|----|-------------|-----|-------------|-----|
| | | MIN | MAX | MIN | MAX |
| lunghezza (a) length (a) | mm | 100 | ∞ | 100 | ∞ |
| larghezza (b) width (b) | mm | 0 | 600 | 0 | 900 |
| altezza (h) height (h) | mm | 0 | 600 | 0 | 720 |

CARATTERISTICHE TECNICHE / TECHNICAL FEATURES

| MACCHINA / MACHINE | | PLURIPAC M6 | PLURIPAC M9 |
|--|----|---|---|
| tensione di alimentazione power supply voltage | V | 230 V 1 Ph | 230 V 1 Ph |
| frequenza di alimentazione power supply frequency | Hz | 50/60 | 50/60 |
| potenza installata installed power | kW | 1 | 1 |
| corrente assorbita current consumption | A | 8 | 8 |
| diametro massimo bobina maximum reel diameter | mm | 700 | 700 |
| larghezza bobina reel width | mm | 600 | 900 |
| tipo film film type | | pluriball, polietilene, poliolefine bubble wrap, polyethylene, polyolefins | pluriball, polietilene, poliolefine bubble wrap, polyethylene, polyolefins |

I contenuti di questo catalogo sono stati verificati al momento della stampa. Robopac si riserva il diritto di modificare in ogni momento le caratteristiche tecniche dei prodotti e degli accessori illustrati nel presente documento. / The contents of this catalog have been verified before the press. Robopac reserves the right to modify in every moment the technical characteristics of the products and accessories illustrated in the present document.